

# CAPPELLO CINESE A DOPPIO CONO

CHINESE CAP

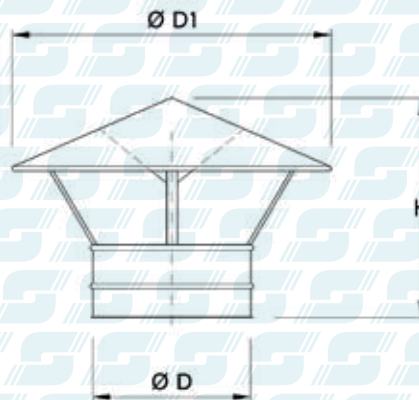

Cod. Art.	ØD [mm]	ØD 1 [mm]	H [mm]	Sp./Thk [mm]	Prezzo €
CPCN-0080	80	200	250	0,8	
CPCN-0100	100	200	250	0,8	
CPCN-0120	120	240	280	0,8	
CPCN-0140	140	280	280	0,8	
CPCN-0150	150	300	280	0,8	
CPCN-0160	160	320	280	0,8	
CPCN-0180	180	360	300	0,8	
CPCN-0200	200	400	300	0,8	
CPCN-0220	220	440	320	0,8	
CPCN-0240	240	480	320	0,8	
CPCN-0250	250	500	320	0,8	
CPCN-0260	260	520	350	0,8	
CPCN-0280	280	560	350	0,8	
CPCN-0300	300	600	350	0,8	
CPCN-0320	320	640	400	0,8	
CPCN-0340	340	680	400	0,8	
CPCN-0350	350	700	400	0,8	
CPCN-0360	360	720	450	0,8	
CPCN-0380	380	760	450	0,8	
CPCN-0400	400	800	500	0,8	
CPCN-0420	420	840	500	0,8	
CPCN-0440	440	880	550	0,8	
CPCN-0450	450	900	550	0,8	
CPCN-0460	460	920	550	0,8	
CPCN-0480	480	960	550	0,8	
CPCN-0500	500	1000	600	1,0	
CPCN-0520	520	1040	600	1,0	
CPCN-0540	540	1080	600	1,0	

Cod. Art.	ØD [mm]	ØD 1 [mm]	H [mm]	Sp./Thk [mm]	Prezzo €
CPCN-0550	550	1100	650	1,0	
CPCN-0560	560	1120	650	1,0	
CPCN-0580	580	1160	650	1,0	
CPCN-0600	600	1200	700	1,0	
CPCN-0620	620	1240	700	1,0	
CPCN-0640	640	1280	700	1,0	
CPCN-0650	650	1300	750	1,0	
CPCN-0660	660	1320	750	1,0	
CPCN-0680	680	1360	750	1,0	
CPCN-0700	700	1400	750	1,0	
CPCN-0720	720	1440	750	1,0	
CPCN-0740	740	1480	750	1,0	
CPCN-0750	750	1500	750	1,0	
CPCN-0760	760	1520	750	1,0	
CPCN-0780	780	1560	750	1,0	
CPCN-0800	800	1600	800	1,0	
CPCN-0820	820	1640	800	1,0	
CPCN-0840	840	1680	800	1,0	
CPCN-0850	850	1700	800	1,0	
CPCN-0860	860	1720	800	1,0	
CPCN-0880	880	1760	800	1,0	
CPCN-0900	900	1800	850	1,0	
CPCN-0920	920	1840	850	1,0	
CPCN-0940	940	1880	850	1,0	
CPCN-0950	950	1900	850	1,0	
CPCN-0960	960	1920	900	1,0	
CPCN-0980	980	1960	900	1,0	
CPCN-1000	1000	2000	900	1,0	

Su richiesta si eseguono spessori e materiali diversi.

Il prodotto può essere realizzato in 4 versioni: • bordo anello • bordo manicotto • liscio • flangiato (con aggiunta costo flangia).

Other thicknesses and materials are available on request.

The product can be produced in 4 different versions: • ring edge • sleeve edge • smooth • flanged (with the additional cost of the flange).